

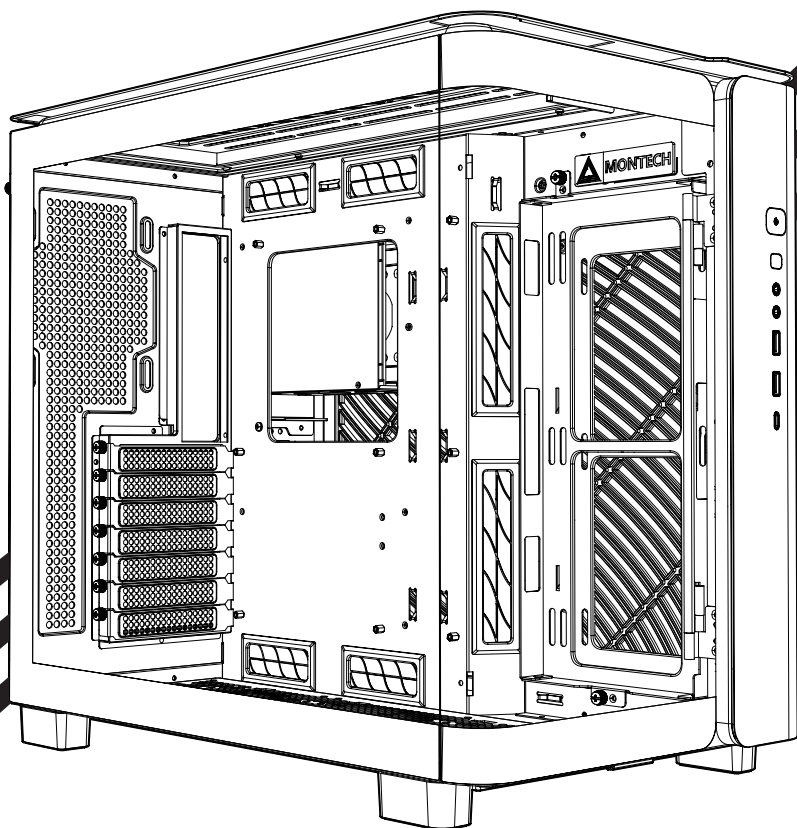

The
Best Value!
MONTECH



KING 95 //

KING 95

Specifications 規格表	02
Accessories Kit 零件包	04
Product Multi-angle Views 產品多視圖	05
Component Breakdown Illustration 部件分解圖	06
Fan(s) Support 風扇支援	08
Hard Drive(s) Support 硬碟支援	08
Fan(s) Installation 風扇安裝	09
Side Fan Bracket Function Guide 側風扇架功能介紹	10
Front Panel Switching Process 面板更換	11
Bottom Panel Hard Disk Bracket Installation 底板硬碟架安裝	12
Side Functional Panel Removal and Installation 側板功能架拆裝	13
Hard Drive Bracket Removal and Installation 硬碟盒拆裝	14
Power Supply Unit (PSU) Installation 電源供應器安裝	15
Hardware Support 硬體支援	16
Dust Filter Mesh 防塵濾網	17
I/O Interface I/O介面	18
Cable Connections 線路連結	19











■規格表 / Specifications /仕様 / 사양 / Spezifikationen / Spécifications / Especificaciones / Especificações / المواصفات

Model	KING 95	
Form Factor	Middle Tower Case	
MB Support	ATX, Micro-ATX, Mini-ITX	
Front I/O	Type-c*1/USB3.0*2/Mic/Audio*1/LED Button	
Color	Black/White/Blue/Red	
Dimensions (L*W*H)	475*300*442mm	
PCI Slots	7	
Materials	SPCC/Tempered glass	
Compatibility/ Maximum	CPU Cooler	175mm
	GPU	420mm
	Power Supply	190mm ATX PSU
Drive Bay	3.5" HDD	5
	2.5"SSD	8
Fan Support	Side	120mm*2/140mm*2
	Top	120mm*3/140mm*2
	bottom	120mm*3/140mm*2
	Rear	120mm*1
Radiator Support	Side	120/140/240/280mm
		(The compatibility with GPU becomes 275mm with 63cm-high water cooling installed.)
	Top	120/140/240/280/360mm
	Rear	120mm

■規格表 / Specifications /仕様 / 사양 / Spezifikationen / Spécifications / Especificaciones / Especificações / المواصفات

Model	KING 95 PRO	
Form Factor	Middle Tower Case	
MB Support	ATX, Micro-ATX, Mini-ITX	
Front I/O	Type-c*1/USB3.0*2/Mic/Audio*1/LED Button	
Color	Black/White/Blue/Red	
Dimensions (L*W*H)	475*300*442mm	
PCI Slots	7	
Materials	SPCC/Tempered glass	
Compatibility/ Maximum	CPU Cooler	175mm
	GPU	420mm
	Power Supply	190mm ATX PSU
Drive Bay	3.5" HDD	5
	2.5"SSD	8
Pre-installed Fan(s)	Side	140mm*2 (Reversed ARGB PWM Fans)
	bottom	120mm*3(Reversed ARGB PWM Fans)
	Rear	120mm*1 (ARGB PWM Fans)
Fan Support	Side	120mm*2/140mm*2
	Top	120mm*3/140mm*2
	bottom	120mm*3/140mm*2
	Rear	120mm*1
Radiator Support	Side	120/140/240/280mm
		(The compatibility with GPU becomes 275mm with 63cm-high water cooling installed.)
	Top	120/140/240/280/360mm
	Rear	120mm

■ 零件包 / Accessories Kit / アクセサリーキット / 액세서리 키트 / Zubehörset / Kit d'accessoires / Kit de accesorios / Kit de acessórios / طاقم الملحقات

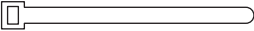
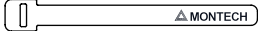
<p>I</p>  <p>X18 Motherboard Screw/SSD Screw</p>	<p>II</p>  <p>X9 HDD Screw</p>
<p>III</p>  <p>X12 HDD bottom screw</p>	<p>IV</p>  <p>X4 SSD Stand-off bolt</p>
<p>V</p>  <p>X12 SSD bottom screw</p>	<p>VI</p>  <p>X12 Fan Screws</p>
<p>VII</p>  <p>X6 PSU/GPU Screws</p>	<p>VIII</p>  <p>X1 MB Stand-off Removal Tool</p>
<p>IX</p>  <p>X1 Thumb Screw</p>	<p>X</p>  <p>X12 Anti-vibration rings</p>
 <p>X5 Zipties</p>	 <p>X4 Magic tape</p>

■ 產品多視圖 / Product Multi-angle Views / マルチアングルビュー / 다각도 보기 /
 Ansichten aus mehreren Winkeln / Vue angles multiples / Vistas multiángulo /
 Vistas multiângulo / عروض متعددة الزوايا

Front view

Back view

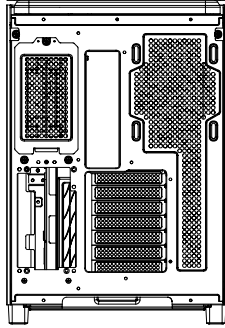
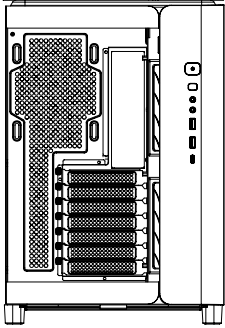

Left side view

Right side view

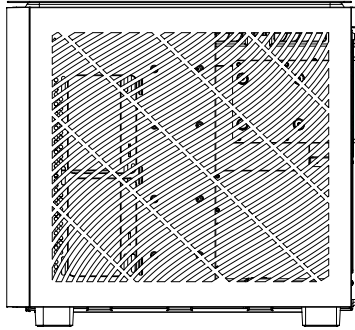
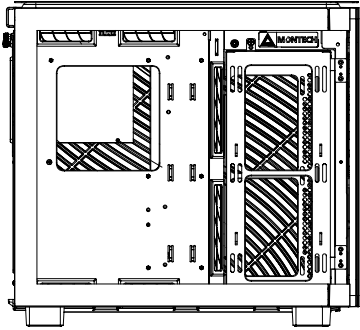

Top view

Bottom view

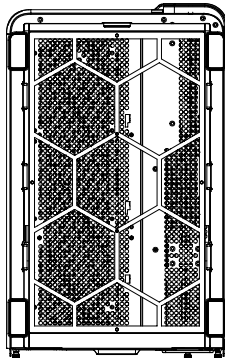
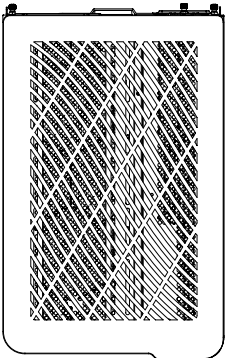

■ 部件分解圖 / Component Breakdown Illustration / コンポーネント分解図 / 구성 요소 분류 체계 그림 / Abbildung der Komponentenaufschlüsselung / Illustration de la répartition des composants / Ilustración de desglose de componentes / Ilustração da subdivisão de componentes / توضیح تعطل المحتوى

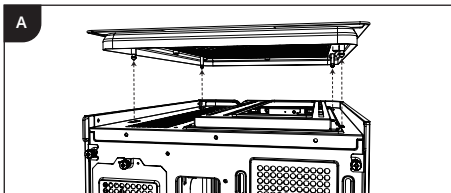
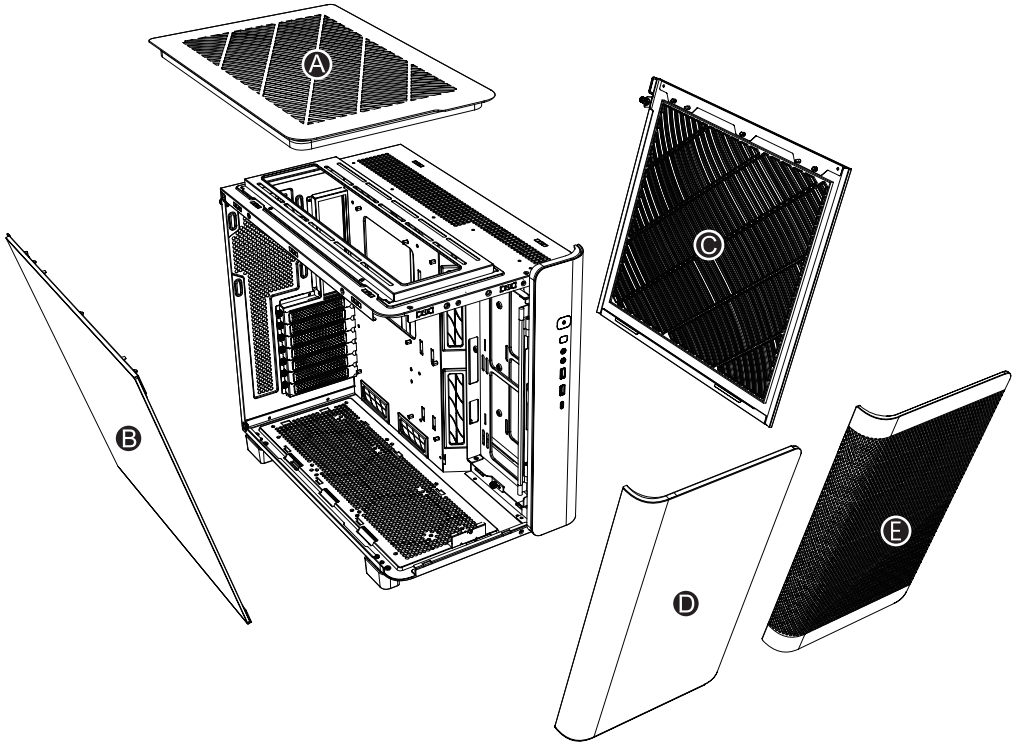

上蓋拆裝 / Top Panel Removal and Installation / トップパネルの取り外し・取り付け / 상부 패널 제거 및 설치 / Obere Blende entfernen und installieren / Retrait et installation du panneau supérieur / Desmontaje e instalación del panel superior / Remoção e instalação do painel superior / تركيب اللوحة العلوية وإزالتها

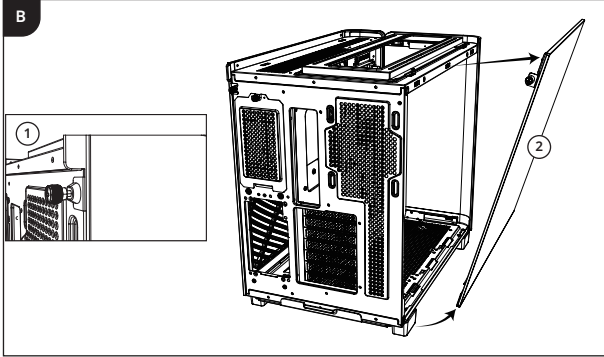

側玻璃面板拆裝 / Side Glass Panel Removal and Installation / サイドガラスパネルの取り外し・取り付け / 측면 유리 패널 제거 및 설치 / Seitliche Glasblende entfernen und installieren / Retrait et installation du panneau latéral en verre / Desmontaje e instalación del panel de vidrio lateral / Remoção e instalação do painel de vidro lateral / تركيب اللوحة الزجاجية الجانبية وإزالتها

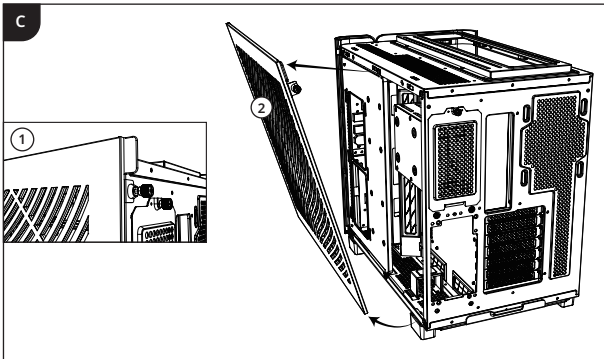

側板拆裝 / Side Panel Removal and Installation / サイドパネルの取り外し・取り付け / 측면 패널 제거 및 설치 / Seitliche Blende entfernen und installieren / Retrait et installation du panneau latéral / Desmontaje e instalación del panel lateral / Remoção e instalação do painel lateral / تركيب اللوحة الجانبية وإزالتها

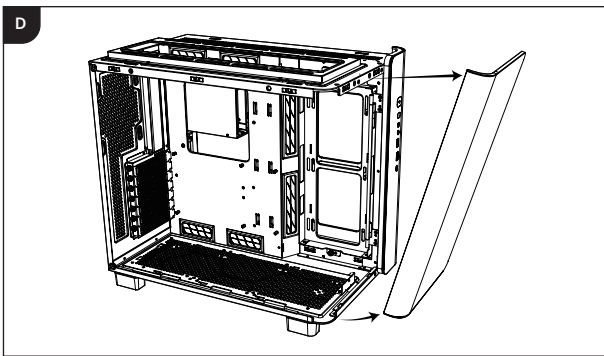

前玻璃面板拆裝 / Front Glass Panel Removal and Installation / フロントガラスパネルの取り外し・取り付け / 전면 유리 패널 제거 및 설치 / Vordere Glasblende entfernen und installieren / Retrait et installation du panneau frontal en verre / Desmontaje e instalación del panel de vidrio frontal / Remoção e instalação do painel de vidro frontal / تركيب اللوحة الزجاجية الأمامية وإزالتها

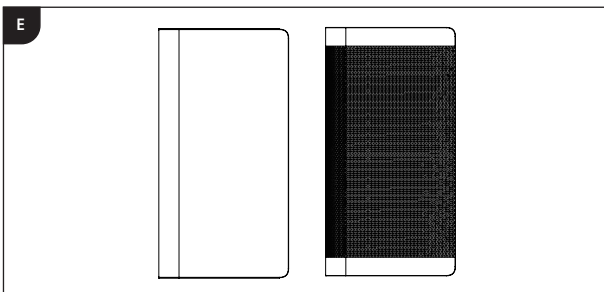

雙面板 / Dual Front Panel / デュアルフロントパネル / 이중 전면 패널 / Duale Frontblende / Double panneau frontal / Panel frontal doble / Painel frontal duplo / اللوحة الأمامية المزدوجة

■ 風扇支援 / Fan(s) Support / ファンのサポート / 팬 지지대 / Lüfterunterstützung /
 Prise en charge du/de ventilateur(s) / Soporte para ventiladores / Suporte para
 ventilador(es) / دعم المروحة (المراوح)

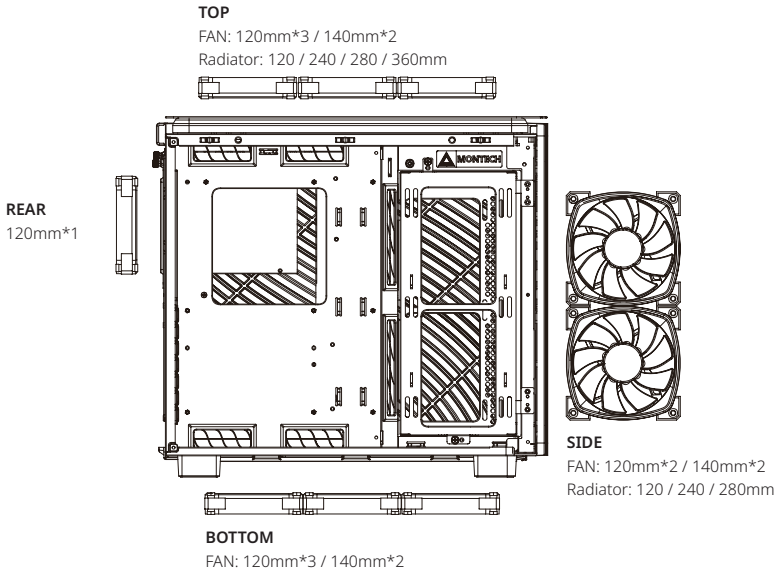

■ 硬碟支援 / Hard Drive(s) Support / 하드 드라이브의サポート / 하드 드라이브 지지
 대 / Festplattenunterstützung / Prise en charge du/de disque(s) dur(s) / Soporte
 para unidades de disco duro / Suporte para disco(s) rígido(s) /
 دعم محرك القرص الصلب (محركات الأقراص الصلبة)

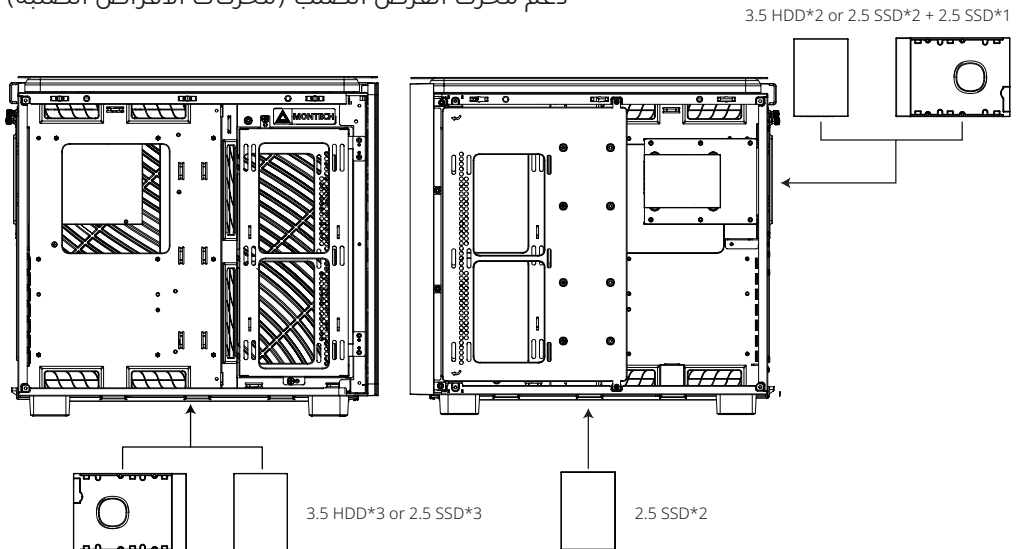

■ 風扇安裝 / Fan(s) Installation / ファンの取り付け / 팬 설치 / Lüfter installieren /
 Installation du/de ventilateur(s) / Instalación de ventiladores / Instalação do(s)
 ventilador(es) / تركيب مروحة(المراوح)

上蓋風扇架安裝 / Top Panel Fan Bracket Installation / トップパネルファンブラケットの取り付け / 상부 패널 팬 브래킷 설치 / Lüfterhalterung an oberer Blende installieren / Installation du support du ventilateur du panneau supérieur / Instalación del soporte del ventilador del panel superior / Instalação do suporte para o(s) ventilador(es) do painel superior / تركيب كتيفة مروحة اللوحة العلوية

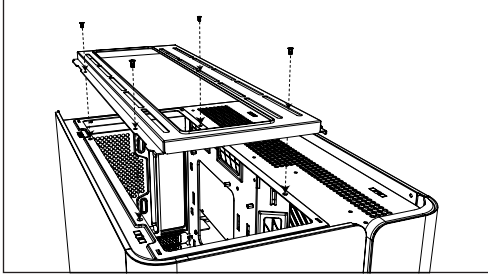

底板風扇安裝 / Bottom Panel Fan(s) Installation / ボトムパネルファンの取り付け / 하부 패널 팬 설치 / Lüfter an unterer Blende installieren / Installation du/de ventilateur(s) du panneau inférieur / Instalación de los ventiladores del panel inferior / Instalação do(s) ventilador(es) do painel inferior / تركيب مروحة اللوحة السفلية

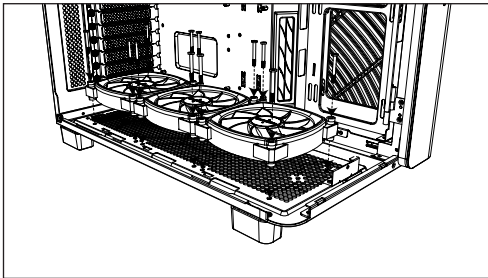

側風扇安裝 / Side Panel Fan(s) Installation / サイドパネルファンの取り付け / 측면 패널 팬 설치 / Lüfter an der seitlichen Blende installieren / Installation du/de ventilateur(s) du panneau latéral/aux / Instalación de los ventiladores del panel lateral / Instalação do(s) ventilador(es) do painel lateral / تركيب مروحة اللوحة الجانبية

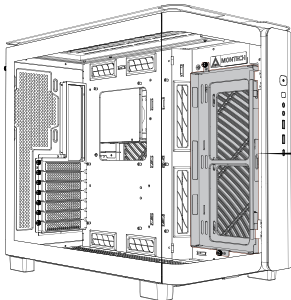

上蓋風扇安裝 / Top Panel Fan(s) Installation / トップパネルファンの取り付け / 상부 패널 팬 설치 / Lüfter an oberer Blende installieren / Installation du/de ventilateur(s) du panneau supérieur / Instalación de los ventiladores del panel superior / Instalação do(s) ventilador(es) do painel superior / تركيب مروحة اللوحة العلوية

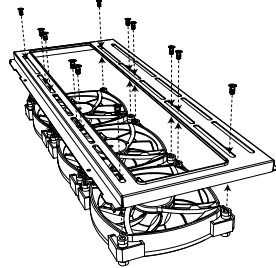

後風扇安裝 / Rear Fan Installation / リアファンの取り付け / 후면 팬 설치 / Hinteren Lüfter installieren / Installation du ventilateur arrière / Instalación del ventilador posterior / Instalação do(s) ventilador(es) traseiro(s) / تركيب مروحة المروحة الخلفية

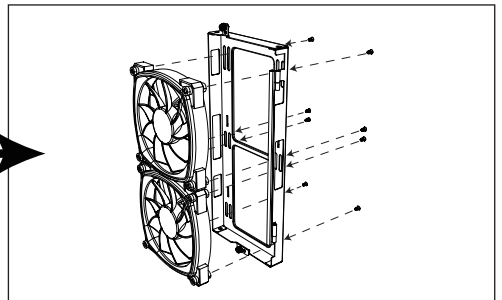
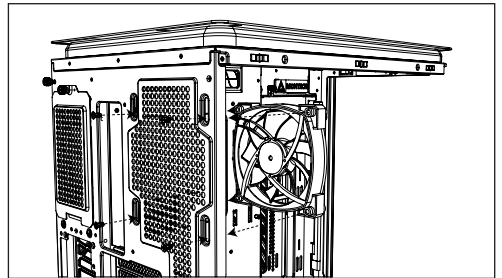

側風扇架功能介紹 / Side Fan Bracket Function Guide / 사이드팬브라켓 기능 가이드 / 측면 팬 브래킷 기능 안내 / Funktionale Führung seitliche Lüfterhalterung / Guide des fonctions du support du ventilateur latéral / Guía de funciones del soporte del ventilador lateral / Guia de funções do suporte do(s) ventilador(es) lateral(ais) / دليل وظيفة كتيفة المروحة الجانبية

側風扇架操作步驟 / Side Fan Bracket Operating Instructions / 사이드팬브라켓의操作方法 / 측면 팬 브래킷 작동 지침 / Betriebsanweisungen seitliche Lüfterhalterung / Instructions d'utilisation du support du ventilateur latéral / Instrucciones de funcionamiento del soporte del ventilador lateral / Instruções de funcionamento do suporte do(s) ventilador(es) lateral(ais) / تعليمات تشغيل كتيفة المروحة الجانبية

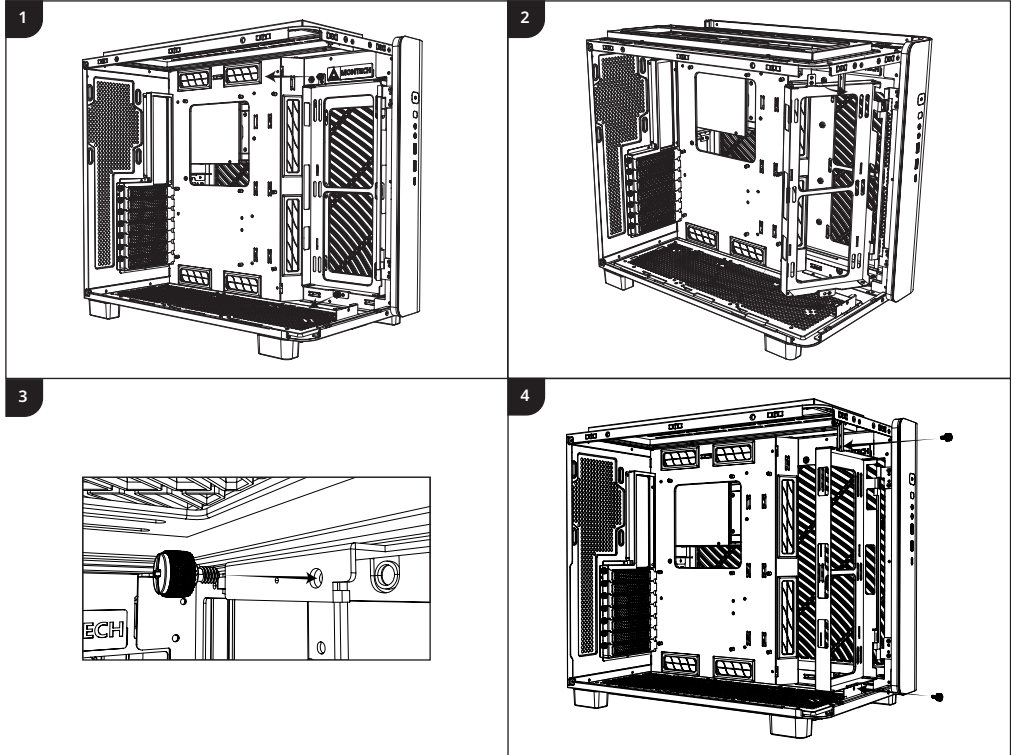

側風扇架操作注意事項 / Side Fan Bracket Operating Precautions / 사이드팬브라켓의操作上的注意事項 / 측면 팬 브래킷 작동 시 주의 사항 / Warnhinweise bei der Bedienung der seitlichen Lüfterhalterung / Précautions d' utilisation du support de ventilateur latéral / Precauciones de funcionamiento del soporte del ventilador lateral / Precauções de funcionamento do suporte do(s) ventilador(es) lateral(ais) / احتياطات تشغيل كتيفة المروحة الجانبية

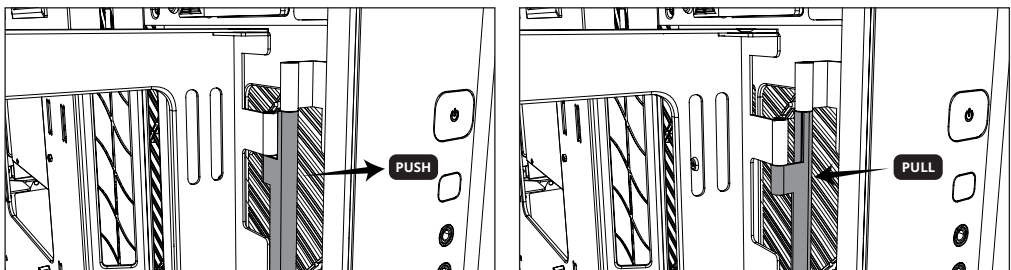

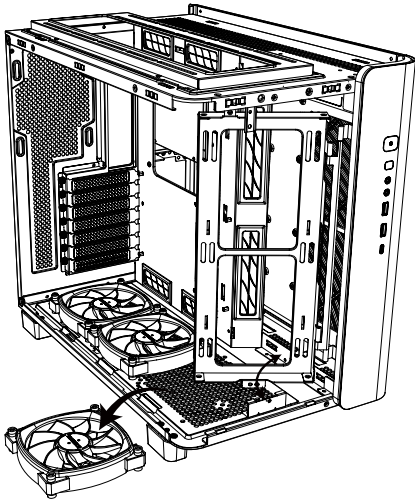

側邊風扇架旋轉時,需先將底板前方的120mm風扇取出,待風扇架轉至定位後,再將風扇安裝回去 / When Rotating the Side Fan Bracket, First Remove the 120mm Fan at the Front Bottom Panel. Once the Fan Bracket is in Position, Re-install the Fan.

■ 面板更換 / Front Panel Switching Process / フロントパネル切り替え方法 / 전면 패널 전환 프로세스 / Vordere Blende wechseln / Processus de changement du panneau frontal / Proceso de conmutación del panel frontal / Processo de mudança do painel frontal / عملية تشغيل اللوحة الأمامية

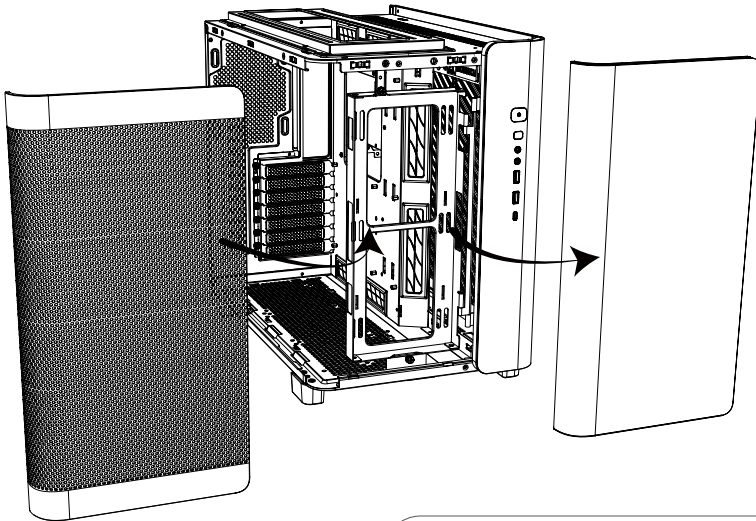

側邊風扇架轉至正面後,可更換為鐵網前面板 / After Rotating the Side Fan Bracket to the Front, Replace the Front Panel with Mesh panel.

■ 底板硬碟架安裝 / Bottom Panel Hard Disk Bracket Installation / ボトムパネルハードディスクブラケットの取り付け / 하부 패널 하드 디스크 브래킷 설치 /
 Festplattenhalterung an unterer Blende installieren / Installation du support de disque dur du panneau inférieur / Instalación del soporte del disco duro del panel inferior / Instalação do suporte do(s) disco(s) rígido(s) do painel inferior /
 تركيب كتيفة القرص الصلب الخاص باللوحه السفلية

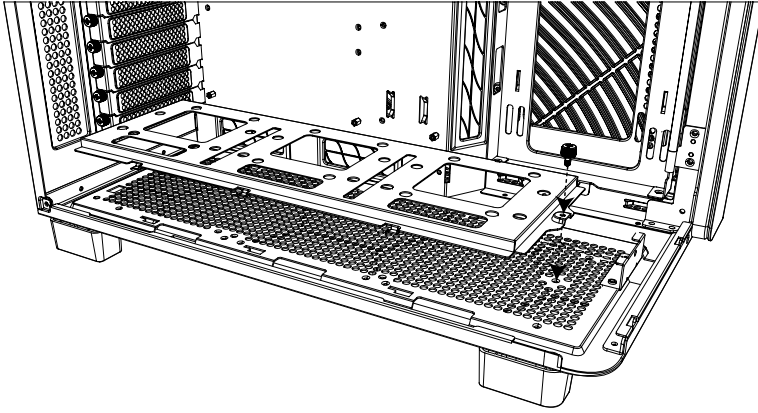

硬碟安裝 / Hard Disk(s) Installation / 하드디스크의取り付け / 하드 디스크 설치 / Festplatte(n) installieren / Installation du/des disque(s) dur(s) / nstalación de discos duros / Instalação do(s) disco(s) rígido(s) / تركيب محرك القرص الصلب (محركات)

HDD

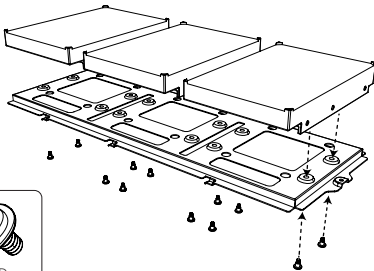

SSD

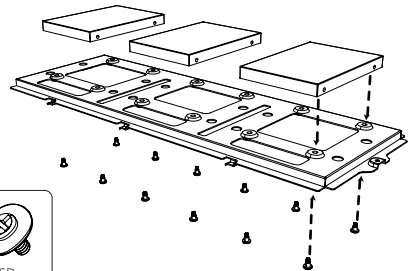

■ 側板功能架拆裝 / Side Functional Panel Removal and Installation / サイド機能パネルの取り外し・取り付け / 측면 기능성 패널 제거 및 설치 / Seitliche funktionale Blende entfernen und installieren / Retrait et installation du panneau fonctionnel latéral / Desmontaje e instalación del panel funcional lateral / Remoção e instalação do painel de funções lateral / تركيب اللوحة الوظيفية الجانبية وإزالتها

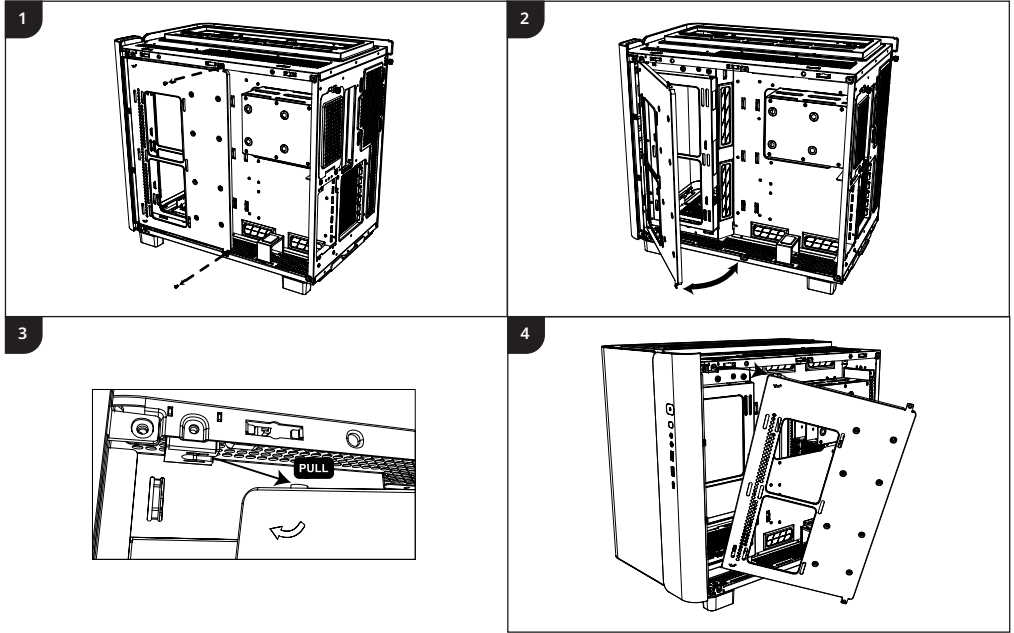

側板功能架支撐 / Side Functional Panel Support(s) / サイド機能パネルのサポート / 측면 기능성 패널 지지대 / Unterstützung seitliche funktionale Blende / Support(s) du panneau fonctionnel latéral / Soportes del panel funcional lateral / Suporte(s) do painel de funções lateral / دعم اللوحة الوظيفية الجانبية (دواعم)

FAN: 120mm*2 / 140mm*2
 Radiator: 120 / 140 / 240 / 280mm

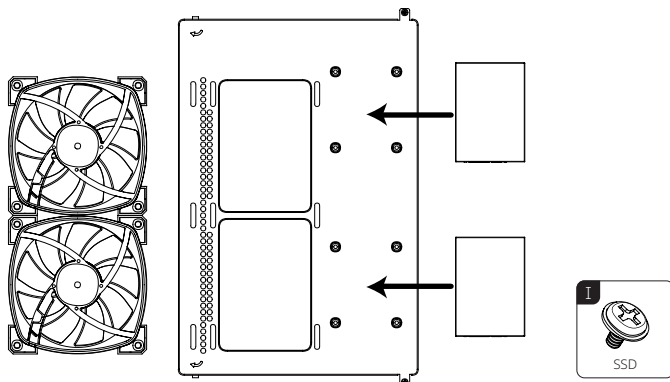

■ 硬碟盒拆装 / Hard Drive Bracket Removal and Installation / ハードドライブブラケットの取り外し・取り付け / 하드 드라이브 브래킷 제거 및 설치 / Festplattenhalterung entfernen und installieren / Retrait et installation du support du disque dur / Desmontaje e instalación del soporte del disco duro / Remoção e instalação do suporte do(s) disco(s) rígido(s) / تركيب كتيفة محرك القرص الصلب وإزالتها

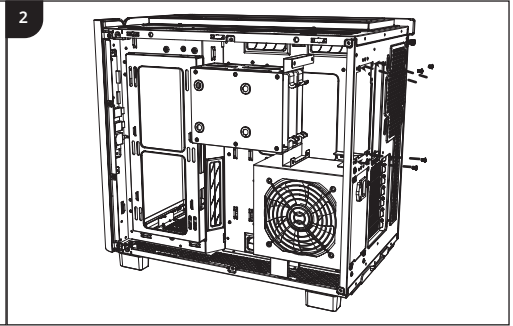
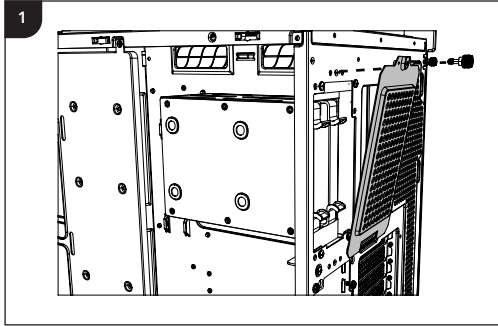

抽取式硬碟架安裝 / Pull-out Hard Drive Tray Installation /引き出し式ハードドライブトレイの取り付け / 착탈식 하드 드라이브 트레이 설치 / Ausziehbarer Festplatteneinsatz installieren / Installation du plateau de disque dur extractible / Instalación de la bandeja extraíble para discos duros / Instalação do tabuleiro de discos rígidos amovível / تركيب درج محرك القرص الصلب القابل للسحب للخارج

SSD安裝 / SSD Installation / SSDの取り付け / SSD 설치 / SSD installieren / Installation SSD / Instalación de la unidad de estado sólido / Instalação do SSD / SSD بطاقة تركيب

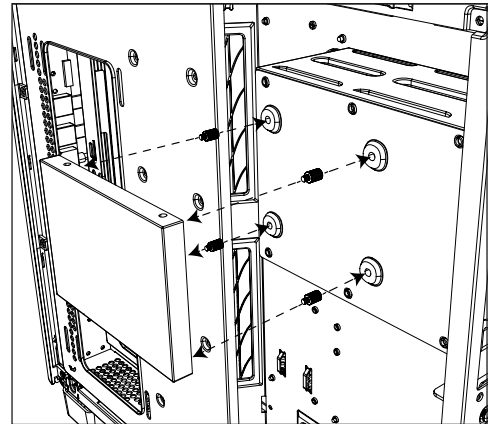
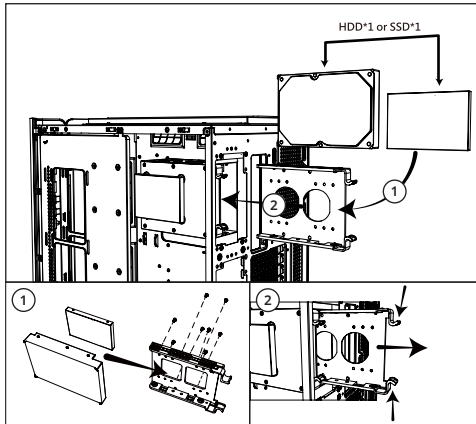

電源供應器安裝 / Power Supply Unit (PSU) Installation / 電源ユニット (PSU) の取り付け / 전원 공급 장치(PSU) 설치 / Netzteil installieren / Installation du bloc d'alimentation (PSU) / Instalación de la unidad de fuente de alimentación (PSU) / Instalação da fonte de alimentação (PSU) / (PSU) وحدة الإمداد بالطاقة تركيب

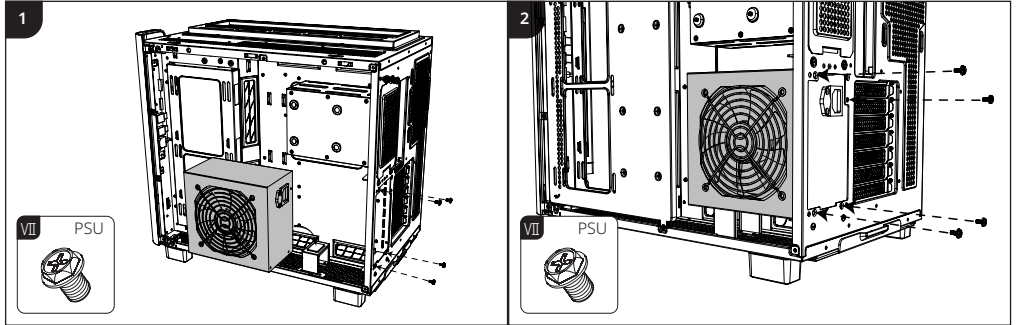

上置電源供應器安裝 / Top-Mount PSU Installation / トップマウントPSUの取り付け / 상단 장착형 PSU 설치 / An der Oberseite montiertes Netzteil installieren / Installation du bloc d'alimentation monté en supérieu / Instalación de la unidad de fuente de alimentación de montaje superior / Instalação da PSU na parte superior / تركيب وحدة المثةبة علويًا

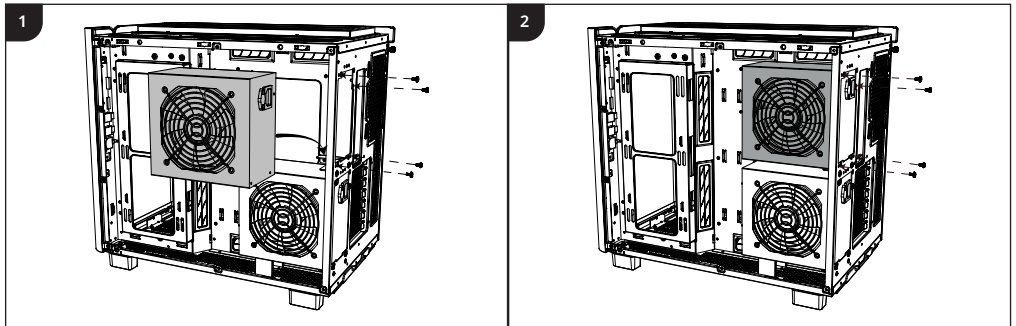

硬體支援 / Hardware Support / 하드웨어의サポート / 하드웨어 지지대 / Hardware-Unterstützung / Support matériel / Soporte de hardware / Suporte para hardware / دعم الجهاز

GPU支援 / GPU Support / GPU의サポート / GPU 지지대 / GPU-Unterstützung / Support du processeur graphique / Soporte de la GPU / Suporte para GPU / دعم وحدة معالجة الرسومات

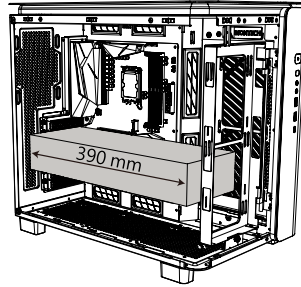
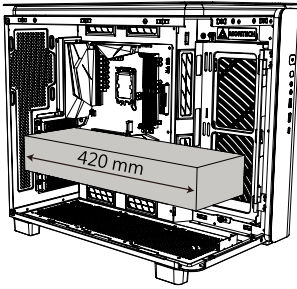

主機板支援 / Motherboard Support / 마ザー보드의サポート / 마더보드 지지대 / Motherboard-Unterstützung / Support de carte mère / Soporte de la placa base / Suporte para placa principal / دعم اللوحة الأم

CPU Cooler 支援 / CPU Cooler Support / CPU쿨러의サポート / CPU 쿨러 지지대 / CPU-Kühlerunterstützung / Support du refroidisseur de processeur / Soporte del refrigerador de la CPU / Suporte para refrigerador da CPU / دعم مبرد وحدة المعالجة المركزية

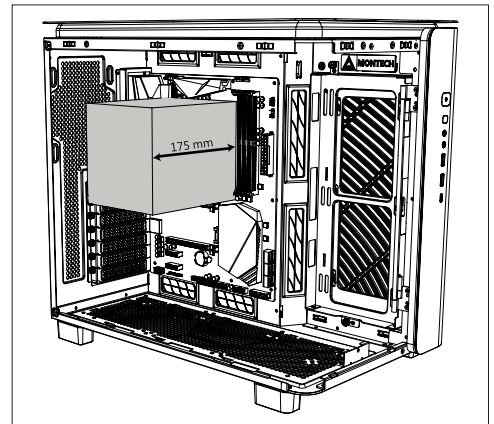
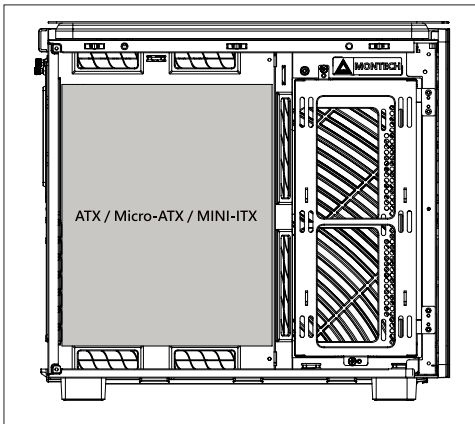

防塵濾網 / Dust Filter Mesh / ダストフィルターメッシュ / 먼지 필터 메쉬 / Staubfiltergitter / Maille du filtre à poussière / Malla de filtro antipolvo / Malha do filtro de pó / شبكة فلتير الغبار

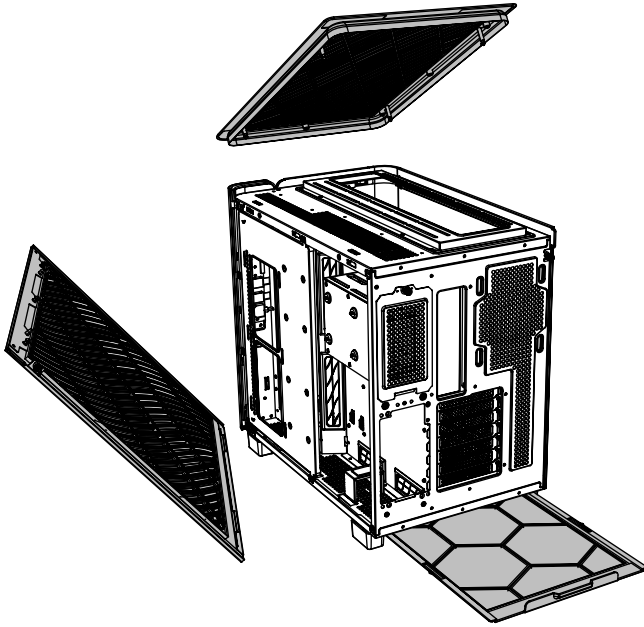

警告 : 防塵網不可拆 / Warning: Dust Filter Mesh is Non-removable / 警告 : ダストフィルターメッシュは取り外し不可 / 경고: 먼지 필터 메쉬는 제거할 수 없음 / Warnung: Staubfiltergitter ist nicht abnehmbar / Avertissement : La maille du filtre à poussière n'est pas amovible / Advertencia: La malla del filtro antipolvo no es extraíble / Aviso: A malha do filtro de pó não é amovível / تحذير: شبكة فلتير الغبار غير قابلة للإزالة

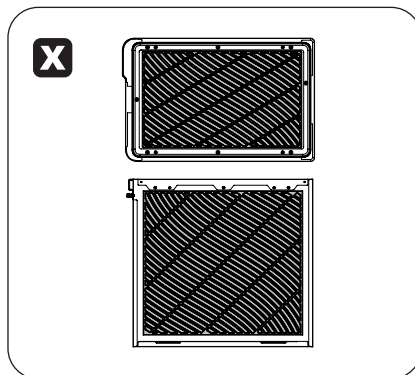

I/O 介面 / I/O Interface / I/O 인터페이스 / I/O 인터페이스 / I/O-Schnittstelle / Interface E/S / Interfaz de E/S / Interface de E/S / واجهة الدخل/الخروج

LED 鍵介紹 / LED Buttons Overview / LED 버튼의 개요 / LED 버튼 개요 / LED-Tasten im Überblick / Aperçu des boutons DEL / Descripción general de los botones LED / Visão geral dos botões LED / LED 按壓裝置介紹

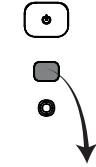
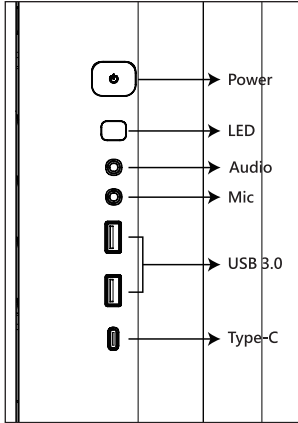

- 【切换模式】：輕按LED鍵
- 【關燈模式】：常按LED鍵五秒
- 【主板同步】：將ARGB線插入主機板後，常按LED按鍵三秒即可同步
- 【Switch lighting mode】：press the LED button to switch between different lighting mode
- 【Turn off the Lighting】：Press the LED button for 5 seconds until the lighting is turned off.
- 【Sync with the motherboard】：Connect the ARGB wire(5V) onto the motherboard, press the LED button for 3 seconds

線路連結(僅限KING95使用) / Cable Connection Exclusive to KING 95 / KING 95 専用ケーブル接続 / KING 95 전용 케이블 연결 / Kabelverbindung exklusiv für KING 95 / Branchement des câbles exclusifs vers KING 95 / Conexión de los cables exclusiva de KING 95 / Ligação de cabos exclusiva do KING 95 / توصيل الكابلات يقتصر على KING 95

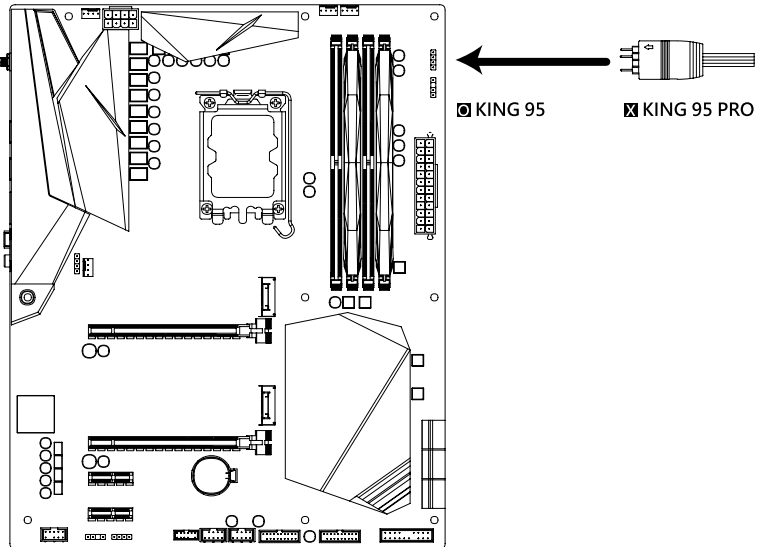

線路連結 / Cable Connections / ケーブル接続 / 케이블 연결 / Kabelverbindungen /
 Branchement des câbles / Conexión de los cables / Ligações de cabos /
 توصيلات الكبلات

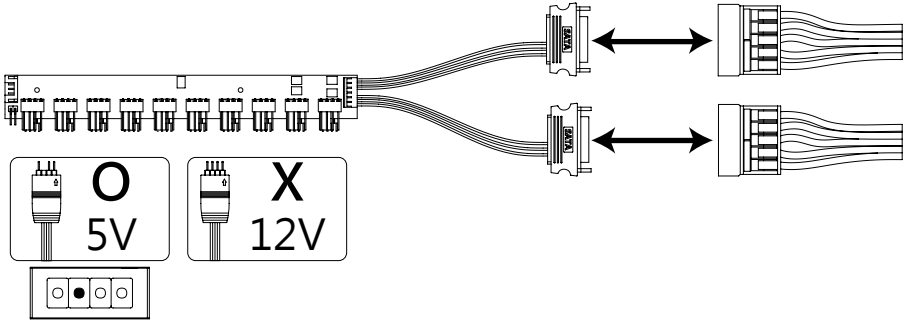

線路連結(僅限KING95使用) / Cable Connection Exclusive to KING 95 / KING 95専用ケーブル接続 / KING 95 전용 케이블 연결 / Kabelverbind-
 ung exklusiv für KING 95 / Branchement des câbles exclusifs vers KING 95 / Conexión de los cables exclusiva de KING 95 / Ligaçãõ de
 cabos exclusiva do KING 95 / KING 95 ًتقتصر على توصيل الكبلات

○ KING 95

✕ KING 95 PRO

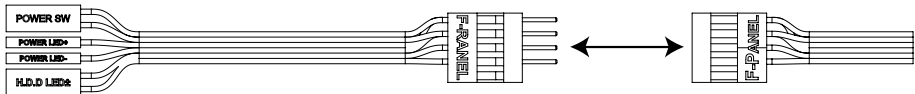

KING 95 //

 **MONTECH**