

FOR THE WINNERS' CIRCLE



ANDASEAT
KAISER 4 GAMING CHAIR OFFICE CHAIR TYPE B

ASSEMBLY INSTRUCTIONS AND USER GUIDE

Thank you for choosing AndaSeat !
Before using this product, please read this manual carefully
and keep it available for future reference.

PACKAGE CONTENTS

1× Backrest
1× Seat Base
1× Wheelbase
2× Armrests (Pre-installed)
1× Magnetic Head Pillow
1× Multi-Functional Tilt Mechanism
1× Accessories Box

Accessories Box Contents

2× Magnetic Side Covers
5× Casters
6× M8 Screws (2pcs Backup)
2× Machine Screws
1× Long Allen Key
1× Gas Piston + Sleeve
1× Height Adjustment Tilt Lever Handle
1× Tilt Lock Lever Handle
1× Safety Cap

ASSEMBLY GUIDE

1. Insert the Casters

Flip the wheelbase upside down on the foam and then insert 5 casters respectively into the legs of the wheelbase.



2. Install the Gas Piston and Sleeve

Turn the wheelbase on the correct side up, then insert the gas piston into the middle of the wheelbase and cover it with the sleeve.

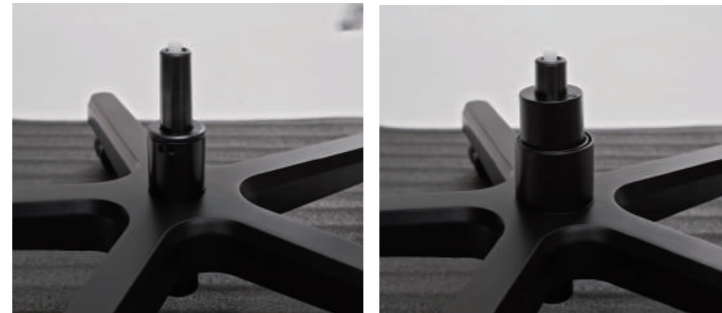

3. Unscrew the Backrest

Remove the 4 pre-installed M8 screws from the backrest using the included Allen key.



4. Attach the Backrest to the Seat

First slide the right-side backrest bracket down onto the right recline bracket. Then insert the M8 screws previously removed from the backrest and screw them halfway.



5. Fix the Left Side of the Backrest

Align the left recline bracket with the screw holes on the left of the backrest. Reinsert the remaining M8 screws halfway, then tighten all 4 screws fully on both sides.



6. Attach the Magnetic Side Covers

Place the magnetic side covers over the backrest brackets respectively, and they will snap magnetically in place.

Tip: The one without a curved shape is the left-side cover.



7. Insert Levers

Line up the grooves inside each lever with the notches and insert fully into the shaft.

Reminder: Be sure to match the "Front" label. If not, the chair may lean forward and need to be reassembled.



8. Set the Chair Facing Down

Now gently lift the chair and place it facing downwards.



9. Secure the Connector to the Seat Base

Connect the cable on the backrest to the pop-out lumbar lever. To do this, open the black box, put the cable's ball ends into the connector, and close the box. Then secure it to the seat base with machine screws (2pcs).

Reminder: The connector is hidden underneath the seat base.

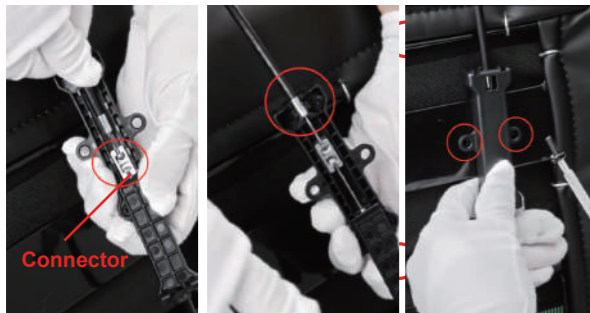

10. Attach Tilt Mechanism

Attach the multi-functional tilt mechanism to the bottom of the seat base. Insert the 4 M8 screws in only halfway, once the screws are correctly placed, tighten them with the Allen key.

Reminder: Make sure the FRONT sign is aligned with the seat front.



13. Remove the Safety Screw

Take off the red screw on the right recline side by hand. This allows the recline mechanism to be used.

Reminder: Properly keep the red screw as it can be re-installed for child safety.

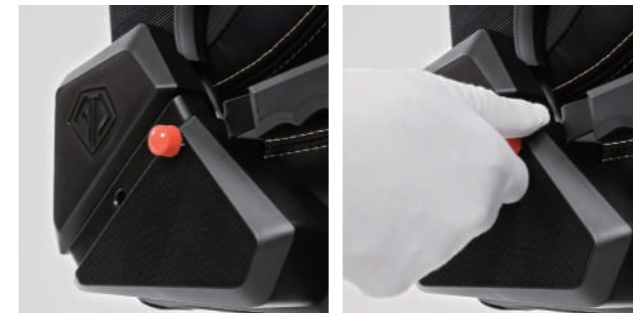

14. Insert the Safety Cap

Insert the safety cap into the hole.



11. Attach the Wheelbase to the Chair

Lift the assembled wheelbase and correctly insert the gas piston into the tilt mechanism's mounting hole.



12. Put the Chair Up

Carefully tilt the chair into an upright position.



15. Assemble Magnetic Head Pillow

Assemble the magnetic head pillow and move it up and down to your preferred position.



Congratulations, the assembly is complete!

USAGE INSTRUCTIONS

Backrest Recline 90°- 135°

Pull up fully and hold the recline lever, lean back slowly until the backrest reaches your desired angle, then release the recline lever to its original position.



Tilt Tension

The adjustment of the tilt tension needs to be based on the height and weight of the individual. Turn the knob clockwise to loosen the rocking tension, anti-clockwise to tighten it. It should not be so tight that there is no movement and not so loose that there is no support.



5D Armrests

1. Press and hold the button to adjust the height of the armrests.
2. Move the armrests left or right.
3. Slide the armrests forward or backward.
4. Rotate the armrests inward or outward.
5. Press and hold the button to fold the armrests upward.



Armrest Adjustment

Adjust the distance between the armrests by loosening the M8 screws at the bottom. Move the armrests to the desired position and then tighten the screws.



Pop-out Lumbar Support

The pop-out lumbar system features up to 24° infinite adjustment. Pop it out with a pull on the lever, lean back into any position, and lock it in with a push on the lever.



Notice

Do not press the backrest while adjusting the lumbar support.
Do not try to turn either knob past its maximum or minimum points.
Do not attempt to turn both knobs at the same time.



Built-in Lumbar Adjustment

In-out (While Seated): Turn the knob on the right side to adjust the curvature of the lumbar support. Clockwise to increase and anti-clockwise to decrease.

Up-down (While Seated): Turn the knob on the left side to adjust the position of the lumbar support. Clockwise to raise and anti-clockwise to lower.

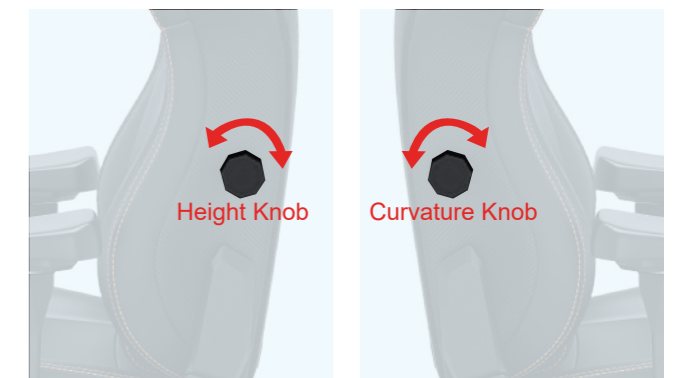

Multi-Functional Tilt Mechanism

Right Lever (While Seated): Flip it up or down to adjust the seat height.

Left Lever (While Seated): Flip it up to unlock the rocking mode and down to lock it.

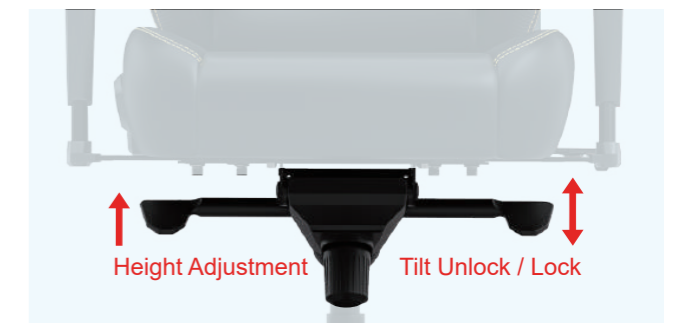

SAFETY INSTRUCTIONS

Size & Capacity

Chair Size	L	XL
Recommended Weight	<120kg (<260lbs)	80-180kg(175-395lbs)
Recommended Height	150-180cm(4'11"-5'11")	181-210cm(5'11"-6'11")

Failure to follow these instructions may result in serious personal injury or property damage.

1. Do not use the chair for purposes other than the manufacturer originally intended.
2. Do not stand on the chair as a ladder.
3. Do not have more than one person on the seat.
4. Do not sit on the edge of the seat.
5. Do not place the chair near flammables.
6. Place it in a dry and cool place.
7. Avoid exposing the chair to direct sunlight or other heat sources.
8. It is recommended to mount the chair on a soft surface to avoid damage to the upholstery.
9. Use a soft and dry cloth for general cleaning and maintenance of the chair. Do not apply corrosive chemicals on the chairs.
10. When transporting the product, proceed with caution.
11. Any modifications and changes of product components that could void your warranty.
12. Warning! Only trained personnel may replace or repair components for height adjustment of seating furniture with energy storage.



Sit in the center of the chair.



Do not stand on the chair.



Do not use the chair with more than one person.



Do not use rocking mode over weight limit.



Do not push the chair around when a person is sitting in it.



Do not push down on the backrest when a person is reclined.



Do not place all your weight on the backrest only.



Do not place your hand or fingers near the recline mechanism.

For warranty information, please visit [Warranty & Return Policy – AndaSeat Help Center](#)

If you have any questions or need any assistance, please contact: sales-support@andaseat.com

For more detailed assembly instructions, please watch this video: https://www.youtube.com/watch?v=T_ulAL8YKvI